

CAPACITY	SYMBOL/ SERIAL NO.	CIRCUIT DIAGRAM
AC 230V, 50Hz		
18W x 2		

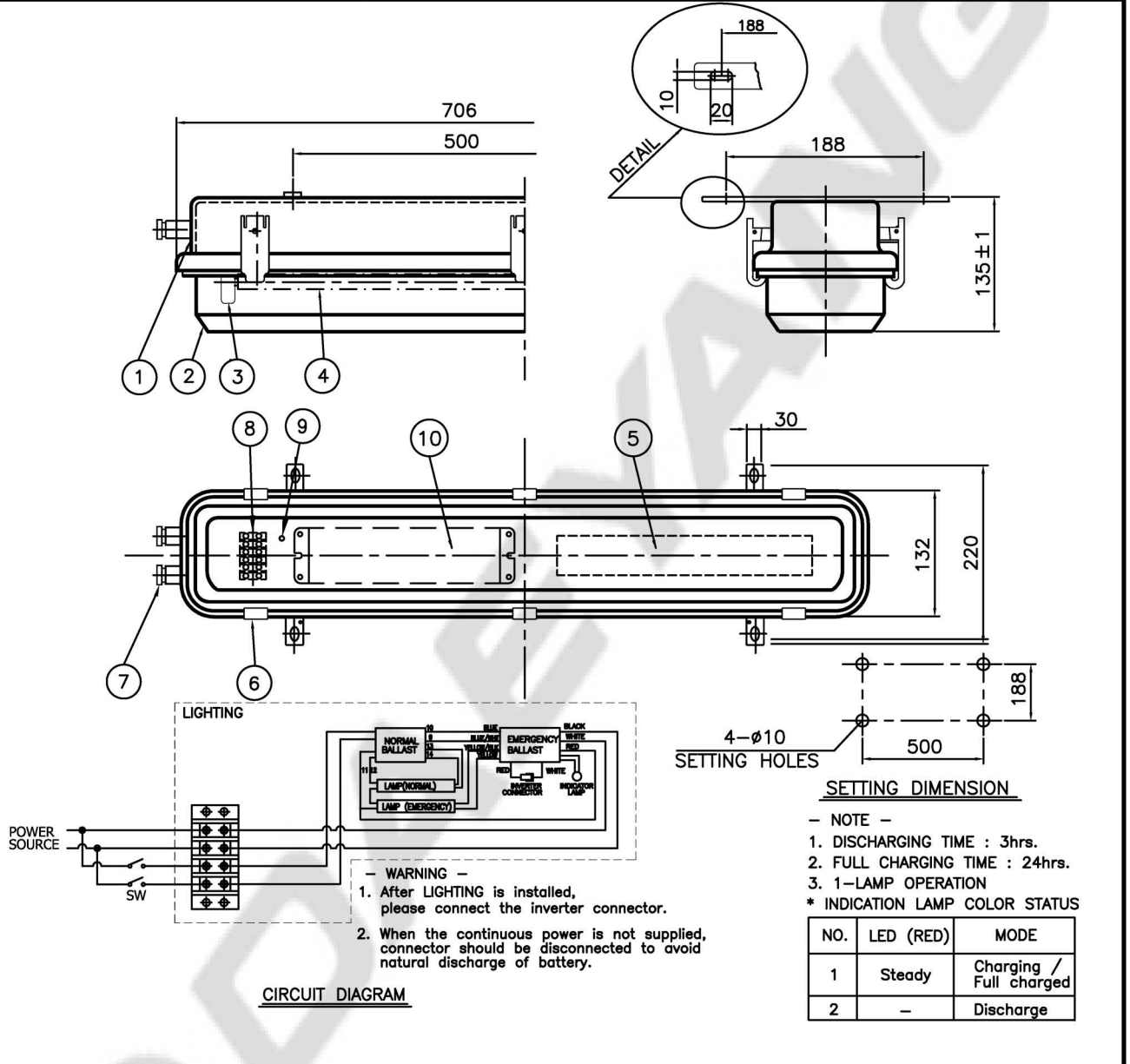

10	EM'CY BALLAST	-	1		5	ELECTRONIC BALLAST	-	2	
9	INSIDE EARTH BOLT	STAINLESS STEEL304	1		4	LAMP	-	2	
8	TERMINAL BLOCK	PHENOL	1	4P	3	LAMP HOLDER	POLYCARBONATE	4	
7	CABLE GLAND	BRASS	2	M24(ϕ 14~17.5)	2	GLOBE	POLYCARBONATE	1	
6	LATCH	STAINLESS STEEL316L	6		1	BODY	STAINLESS STEEL316L	1	
NO	NAME OF PARTS	MATERIAL	Q'TY	REMARKS	NO	NAME OF PARTS	MATERIAL	Q'TY	REMARKS

APPROVED	B. K. KIM	UNIT	MM	TITLE; FLUORESCENT CEILING LIGHT (SURFACE, BATTERY BACKUP TYPE) FOR MARINE USE
CHECKED		SCALE	N/S	
DRAWING	B. I. KIM	COLOR	N-9.3	
DATE	2015.12.04	IP	67	

DAEYANG	MODEL NO.	FL220WS-0235EIUWNMBb2w17h12	WEIGHT	6.4 Kg
	DWG NO.	L11450934	SHEET NO.	